

**BELT MACHINES**

**GK 950 / 960 B SERIES**

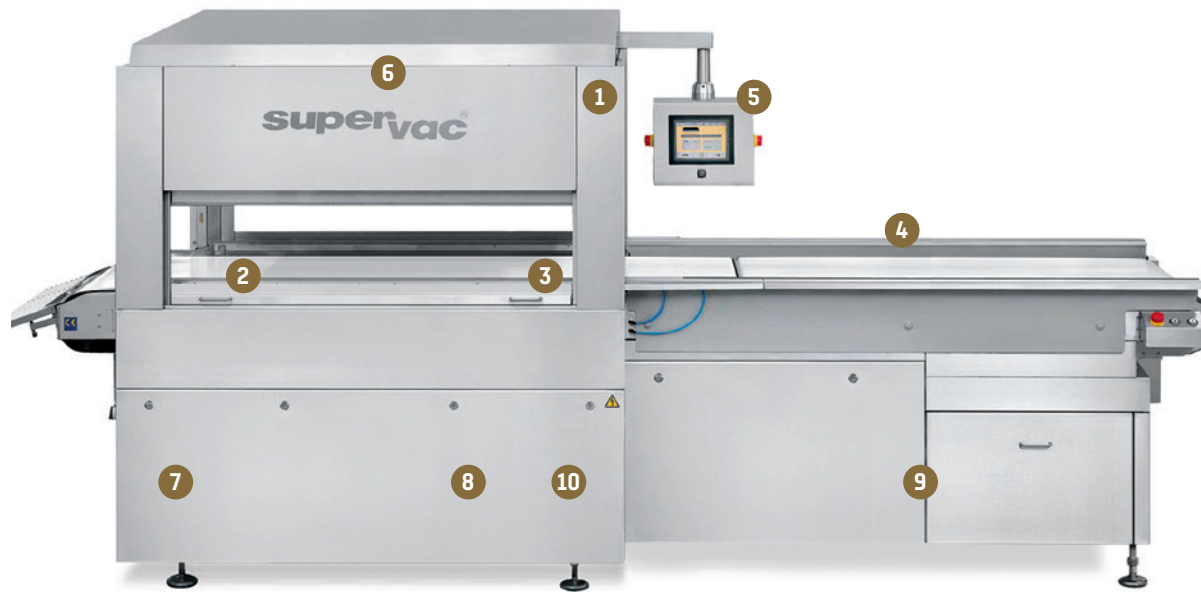



## Your benefits

- ❶ Rugged stainless steel construction for maximum durability.
- ❷ Double biactive sealing bars for firm and reliable seals.
- ❸ Various options available for a the perfect cut-off of protruding bag material.
- ❹ Several sealing bar heights to adjust to the product.
- ❺ Touch screen for simple and clear operation.
- ❻ Various heights in the vacuum chamber for optimal adjustment to the product.
- ❼ Use of tried-and-tested electronics and pneumatics components.
- ❽ Optimized BUSCH vacuum pump combinations to choose from.
- ❾ Hygienic design – easy to clean.
- ❿ Control box heating.



## Touch screen

- ◆ Simple and easy operation by finger pressure directly on the screen.
- ◆ 7.7" color display.
- ◆ Electronic monitoring of the work process and displays in comprehensible and well-arranged on-screen menus.
- ◆ 20 programs activated.
- ◆ Programs can be locked by password.
- ◆ Alphanumeric display for individual program naming, e.g. product name, bag material, etc.
- ◆ Integrated high-precision digital vacuum meter.
- ◆ Chamber vacuum displayed in mbar.
- ◆ Evacuation, optionally:
  - ◆ Optimum – up to the evaporation point.
  - ◆ Evacuation time given in tenths of a second.
  - ◆ Final vacuum given in mbar.
  - ◆ in intervals.
- ◆ Sealing time in tenths of a second.
- ◆ Cooling time in tenths of a second.

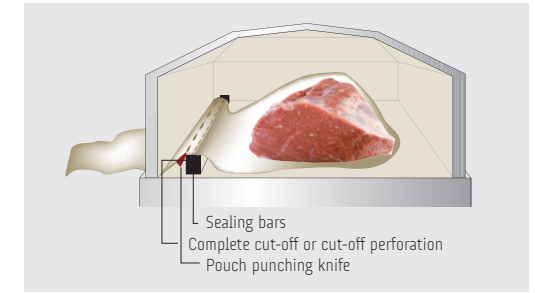
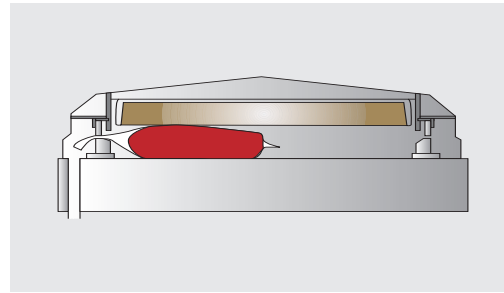
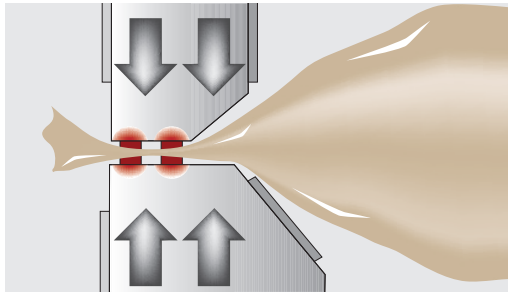

The **double biactive high-pressure sealing** and the **spring-loaded resistance wires** belong to the standard equipment and ensure safe and reliable seals despite folds, grease and moisture in the seal area. Springs keep the resistance wires in the correct track even with continuous operation.

**Rigid lid covering** shortens the evacuation time and provides for ideal cycle times.

**Complete cut-off** means that the protruding bag material of the packages is cut off directly in the vacuum chamber. The exhaust system sucks the bag remains into an external container located underneath the loading belt so manual removal of the excessive bag material is no longer necessary.

The **pouch punching knives** are necessary so that the package can be evacuated even if the bag opening protrudes from the chamber.

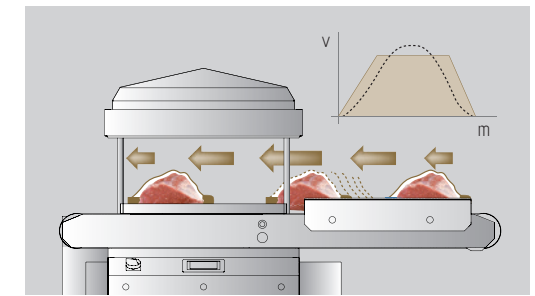

**Water-cooled sealing bars** increase the durability of the Teflon and the sealing wires.

Various **lid heights**:

- GK 952B** – with a lid height of 230 mm.
- GK 953B** – with a lid height of 300 mm.
- GK 962B** – including loading belt (1 operator) – lid height of 230 mm.
- GK 963B** – including loading belt (1 operator) – lid height of 300 mm.

An **indexing loading belt** supports ergonomic and swift loading of the machine and is a prerequisite for later automation of the loading area.

**Soft start and stop of the conveyor belt** prevents the product from slipping during transfer to the vacuum chamber through controlled acceleration and gentle braking.

### Standard equipment

- ◆ Touch screen control.
- ◆ Double biactive high-pressure sealing.
- ◆ Shrink bag equipment.
- ◆ Quick easing of tension of the conveyor belt for easy cleaning.
- ◆ Gentle start and stop of the conveyor belt.
- ◆ Dual evacuation system.
- ◆ Temperature-controlled switch box heating.

### Options

- ◆ Pouch punching knife.
- ◆ Cut-off perforation.
- ◆ Complete cut-off with exhaust system.
- ◆ Water-cooled sealing bars.
- ◆ Conveyor belt with cross profiles for round products (GK952B/953B).
- ◆ Outfeed rollers 250 mm or 500 mm.
- ◆ Booster and rotary van pump combinations.



*Construction made of corrosion-resistant stainless steel.  
Cleaning and hygiene-friendly machine design.*

# GK 950 / 960 B SERIES



## Technical data

Chamber size		1690 x 1110 mm
Lid height	GK 952B / GK 962B	230 mm
	GK 953B / GK 963B	300 mm
Sealing length		2 x 1600 mm
Spacing between bars		830 mm
Fixed sealing bar height		45, 65 oder 85 mm
Other sealing heights		on request
Compressed air consumption		180 NLPM 6 bar
Power supply (without vacuum pump) approx.		4 kW
Built-in booster pump, frequency-controlled		1250 m <sup>3</sup> /h
External vacuum pump		630 m <sup>3</sup> /h
Other pump systems		on request
Total weight without pump		approx. 1800 kg

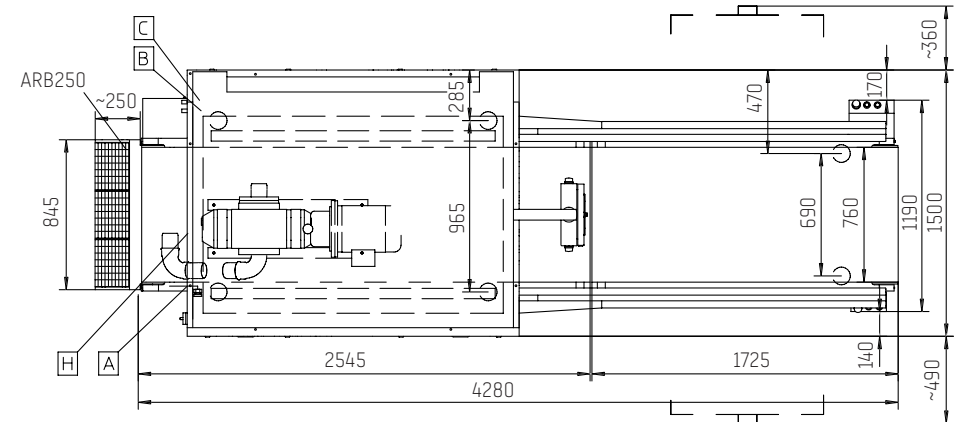
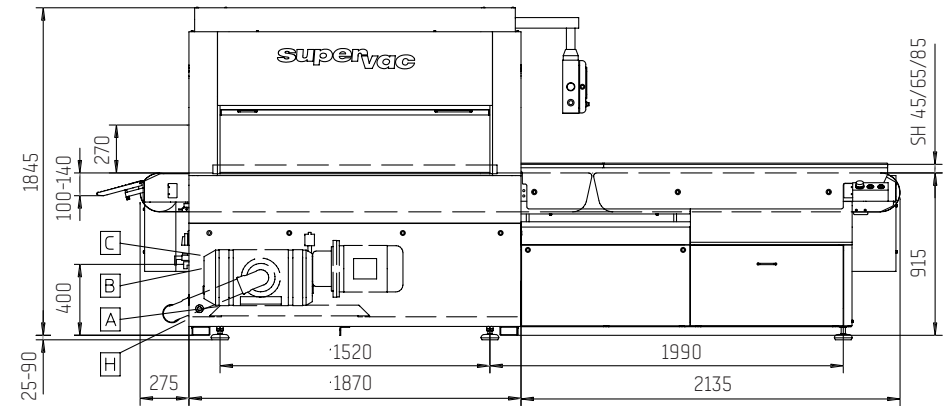

**A** Power supply    **B** Compressed air connection    **C** Water supply    **H** Vacuum connection



**supervac**   
FIRST CLASS PERFORMANCE

**Supervac Maschinenbau GmbH**  
Kalterer Gasse 10  
2340 Mödling | Austria

**T:** +43 2236 50 25 00

**E-mail:** [office@supervac.at](mailto:office@supervac.at)  
**Web:** [www.supervac.at](http://www.supervac.at)