

**BELT MACHINES**

GK 1600 B

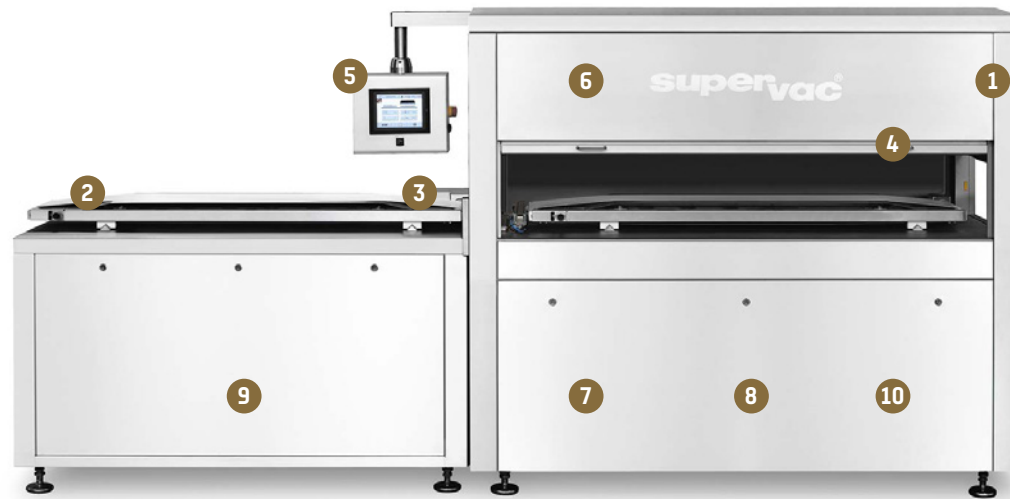



## Your benefits

- 1 Rugged stainless steel construction for maximum durability.
- 2 Double biactive sealing bars for firm and reliable seals.
- 3 Various options available for a the perfect cut-off of protruding bag material.
- 4 Several sealing bar heights to adjust to the product.
- 5 Touch screen for simple and clear operation.
- 6 Various heights in the vacuum chamber for optimal adjustment to the product.
- 7 Use of tried-and-tested electronics and pneumatics components.
- 8 Optimized BUSCH vacuum pump combinations to choose from.
- 9 Hygienic design – easy to clean.
- 10 Control box heating.



## Touch screen

- ◆ Simple and easy touch-screen operation.
- ◆ 7.7" color display.
- ◆ Electronic monitoring of the work process and displays in comprehensible and well-arranged on-screen menus.
- ◆ 20 programs activated.
- ◆ Programs can be locked by password.
- ◆ Alphanumeric display for individual program naming, e.g. product name, bag material, etc.
- ◆ Integrated high-precision digital vacuum meter.
- ◆ Chamber vacuum displayed in mbar.
- ◆ Evacuation, optionally:
  - ◆ Optimum – up to the evaporation point.
  - ◆ Evacuation time given in tenths of a second.
  - ◆ Final vacuum given in mbar.
  - ◆ in intervals.
- ◆ Sealing time in tenths of a second.
- ◆ Cooling time in tenths of a second.

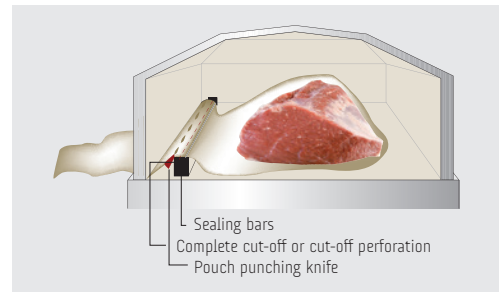
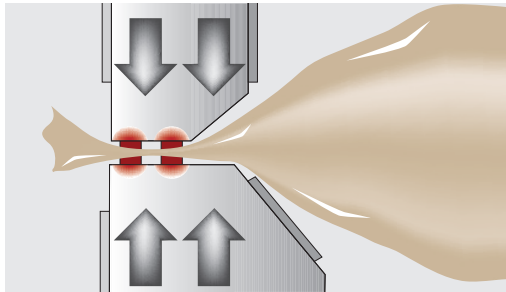

The **double biactive high-pressure sealing** and the **spring-loaded resistance wires** are standard equipment and ensure safe and reliable seals despite folds, fats, oils or moisture in the seal area. Springs keep the resistance wires in the correct track even with continuous operation.

The **cut-off perforation** allows easy removal of protruding bag material after removal of the packages.

The **pouch punching knives** are necessary so that the package can be evacuated even if the bag opening protrudes from the chamber.

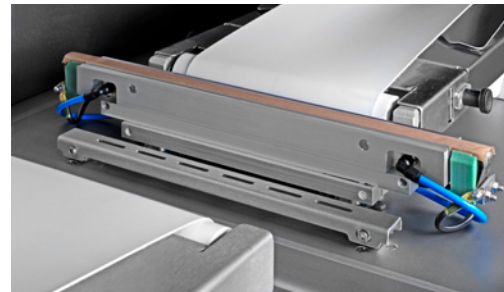

**Height-adjustable sealing bars**  
Perfect look and flexibility through adjustment to different product heights.

**Water-cooled sealing bars** increase the durability of the Teflon and the sealing wires.

A **indexing loading belt** supports ergonomic and swift loading of the machine and is a prerequisite for later automation of the loading area.

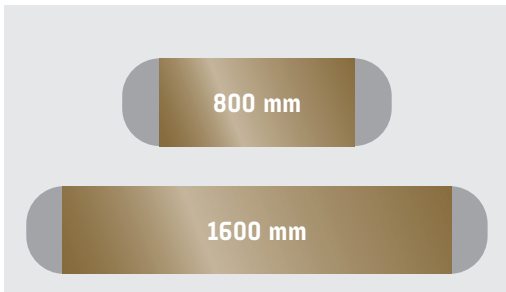

- Edge pieces that cannot be used.
- Usable zones of the slicing-logs.

On a GK 1600 B, slicing-logs of a length of up to 1600 mm can be packaged, reducing the loss rate at the ends of the slicing-logs.

## Standard equipment

- ◆ Touch screen control.
- ◆ Double biactive high-pressure sealing.
- ◆ Quick easing of tension of the conveyor belt for easy cleaning.
- ◆ Gentle start and stop of the conveyor belt.
- ◆ Fixed sealing heights optional in 45, 55, 65 or 75 mm.
- ◆ Convex, i.e. slightly bent up, chamber belt.

## Options

- ◆ Pouch punching knife.
- ◆ Cut-off perforation.
- ◆ Water-cooled sealing bars.
- ◆ Sealing height adjustable in 2 steps 45 / 75 mm.
- ◆ Flat chamber belt.
- ◆ Driven infeed and outfeed belt.
- ◆ Booster and rotary van pump combinations.



*Constructed of corrosion-resistant stainless steel.  
Easy-to-clean, hygiene-friendly machine design.*

# GK 1600 B



## Technical data

Chamber size	1835 x 505 mm
Sealing bar length	405 mm
Max. product length	1600 mm
Max. product height	150 mm
Compressed air consumption	120 NLPM 6 bar
Power supply (without vacuum pump) approx.	3 kW
Built-in booster pump frequency-controlled	1250 m <sup>3</sup> /h
Rotary vane pump	630 m <sup>3</sup> /h or 2 x 250 m <sup>3</sup> /h
Total weight without pump	approx. 1800 kg

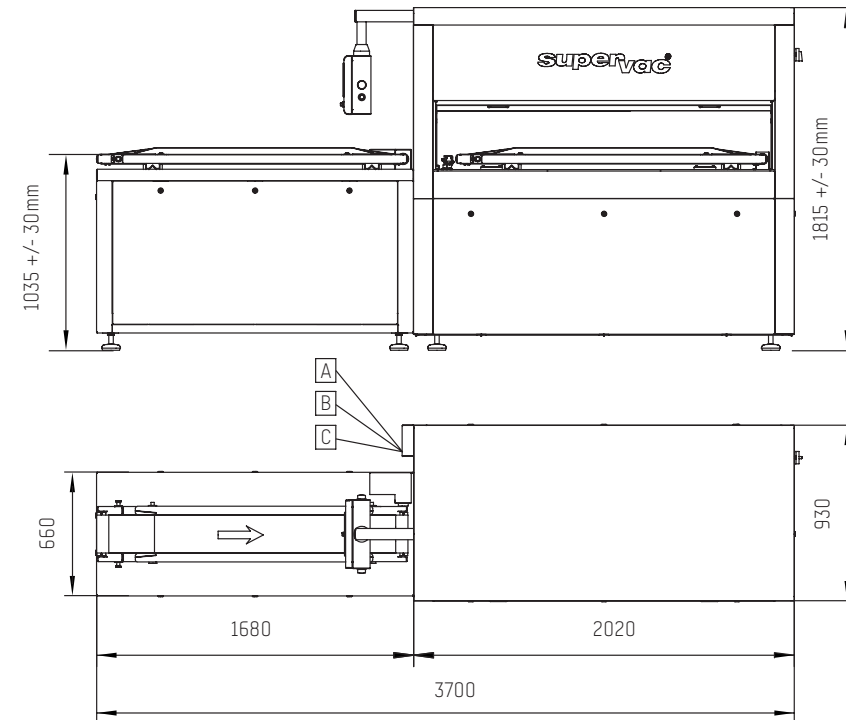

**A** Power supply

**B** Compressed air connection

**C** Water supply



**supervac**   
FIRST CLASS PERFORMANCE

**Supervac Maschinenbau GmbH**  
Kalterer Gasse 10  
2340 Mödling | Austria

**T:** +43 2236 50 25 00

**E-mail:** [office@supervac.at](mailto:office@supervac.at)  
**Web:** [www.supervac.at](http://www.supervac.at)